

## PILOT SCALE THICK JUICE DECOLORIZATION USING FRACTAL EQUIPMENT (ASSBT 2003)

Vadim Kochergin, Tim Pryor, William Jacob  
Amalgamated Research, 2531 Orchard Dr. East, Twin Falls, ID 83301, USA

### **Abstract**

Fractal distributors have been proven to improve fluid distribution in chromatographic applications. Recent reports also demonstrate that fractal distribution principles are very useful in ion exchange softener applications – significantly reducing resin requirements and allowing thin juice exhaustion flowrates as high as 500 BV/hr. An effort has now been made to expand fractal distribution principles to thick juice decolorization with the goal of reducing resin inventories and improving operational characteristics. The results of a pilot study are presented where highly colored thick juice was decolorized with strong base resin. Color removal is compared for conventional and shallow resin bed height. Potential utilization of softening equipment during the off-campaign period for decolorization of thick juice streams is discussed.

### **Introduction**

Engineered fractals for fluid distribution in industrial process equipment have been in use for over a decade. Recently Kearney (2001) reported the application of fractal distributors in softener equipment. Significant reduction in equipment size and resin requirements was observed. For example, in the case of thin juice softening with weak cation resin use of fractal equipment resulted in 10-fold reduction of equipment size along with virtual elimination of pressure drop. Use of fractals has facilitated creation of a new generation of softeners that are specifically designed to take full advantage of fractal distribution characteristics.

Although it is a factor of major importance, fluid distribution is often overlooked in ion exchange or adsorption vessel design. Fluid is usually distributed through perforated radial or lateral pipes or nozzles. These designs do not allow for uniform residence time within a distributor, which results in “spreading” of the concentration front and reduction in process efficiency. Increase in resin bed height is perceived as a standard approach to remedy the situation. This proportionally increases pressure drop and thus, limits equipment throughput. It has been shown, however, that due to poor radial redistribution within the resin bed, there is no practical sense in increasing bed height to compensate for initial liquid maldistribution. Since flowrates of juice and regenerant vary during different process steps, it is very difficult to design a distributor for high turndown ratio using the conventional approach. With fractal distributors these problems have been resolved. It had been demonstrated in many tests that fractals provide uniform distribution within a wide range of flowrates. It is also critical that fractals do not require pressure drop as a design parameter assuring good fluid distribution.

In our recent paper (Kochergin, 2001) it was suggested that fractal equipment could be successfully applied to decolorizing applications. The goal of the current paper is to present the results of pilot scale thick juice decolorization. An effort has been made to simulate the operation of a short bed fractal decolorizer and provide a comparison with conventional operation.

### Experimental Installation and Procedure

An automated experimental installation was used to evaluate decolorization of highly colored thick juice. A simplified diagram of the installation is shown in Figure 1.

**FIGURE 1**  
**Diagram of the experimental installation**

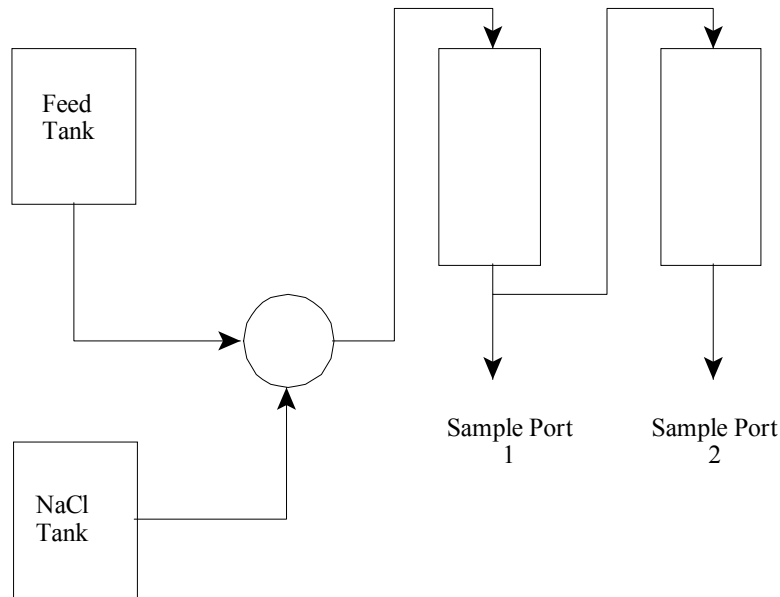

Each of the 3 inch-diameter, 1 ft. long glass columns connected in series was filled with 1.3 liters of anion exchange resin. A sample of strong base macroreticular acrylic based resin Amberlite FPA 98Cl (chloride form) was supplied by Rohm and Haas Company. This resin is usually recommended for projects requiring relatively high color removal efficiency. Liquid was distributed in the columns via ARI's fractal distributors. Both distributors and collectors were constructed to match the distribution density in large-scale equipment to provide for reliable scale-up to industrial size columns. Sample ports were located at the exit of both the first and second column. Columns were equipped with pressure transducers to measure pressure drop across the resin bed. Syrup temperature was measured manually as the samples were taken.

Samples of thick juice used in all tests were supplied by one of ARi's customers. Typically feed thick juice color fluctuated within the range 7500-8000 ICUMSA units. Feed syrup concentration was about 67% DS. Although syrup temperature in the feed tank was maintained at 80°C, we have observed a certain temperature gradient along the column length. Actual temperature in the first column was around 60EC, second column – around 55EC. Suggested operating conditions for Amberlite FPA98 (from the Rohm and Haas applications sheet) are shown in Table 1.

**TABLE 1**  
**Suggested operating parameters**

Operating temperature,EC	80
Minimum bed depth, mm	700
Service flowrate, BV/hr	2-4

Bed depth in each column (as loaded) was 300 mm. Because of resin shrinkage during the process cycle the actual bed depth was about 20% shorter. Feed syrup flowrate was maintained at 3 BV (bed volumes)/hour based on resin volume in **both** columns. Note, that this flowrate is equivalent to double loading based on volume of resin in just one column.

All analytical procedures were in correspondence with ICUMSA recommendations. Particle size analysis was performed using a Malvern Mastersizer 2000 instrument. Each decolorization cycle included the following sequence of operations.

1. Downflow sweet-on
2. Downflow decolorization cycle
3. Upflow or downflow sweet-off
4. Fast upflow backwash
5. Downstream regeneration
6. Regenerant rinse

In order to determine the influence of the number of regeneration cycles on resin integrity and characteristics an additional automated 1 inch-diameter glass column with 1 ft. bed height was installed. The column was automatically exhausted and regenerated every 2-3 hours.

## **Results and Discussion**

### ***Decolorization Tests***

The option of taking syrup samples at the exits of both columns allowed us to evaluate two sets of data simultaneously. Sampling of the syrup after the first column provided information on the performance of a 1 ft.- long column with double loading as compared with the original loading calculation (note, that the original resin loading was calculated based on the volume of resin in *two* columns). If only half of the resin is used with equivalent color removal, resin productivity is doubled. Regenerant requirements in each case should be the same for either one or two columns in series.

A sample of the test data is shown in Table 2. The second column effluent color always lags behind the effluent color out of the first one. At the start of the cycle, when the first column is receiving first batches of syrup, the second column does not have syrup yet. Later in the cycle, when the first column is fully exhausted (or loaded), the second column continues decolorization process. We have plotted the experimental data in Figure 2 for each column as a function of effluent color vs. cumulative bed volumes.

**TABLE 2**  
**A sample of decolorization data**  
**(Feed thick juice color –7545 ICUMSA units)**

Minutes into cycle	Color, ICUMSA	
	Column 1	Column(1+ 2)
20	2905	1854
40	3607	2484
60	4119	2822
80	4699	3195
100	5052	3608
120	5391	3957
140	5497	4234
160	5823	4528

**FIGURE 2**  
**A sample of thick juice decolorization data**

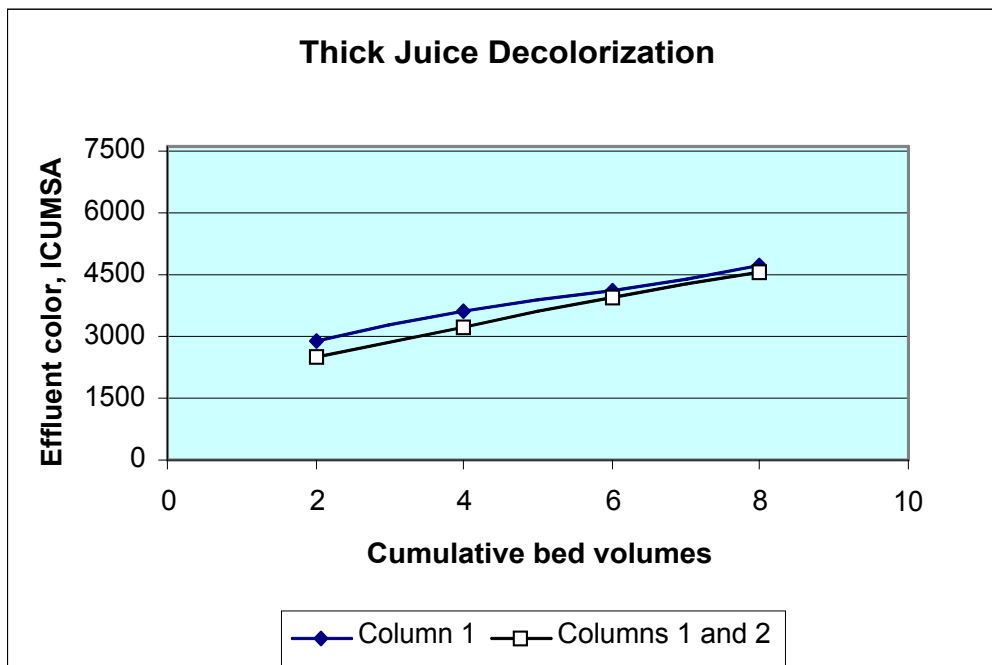

It is important that the total cumulative bed volumes for column 2 was calculated based on resin volumes in columns 1 and 2. If the process were kinetically limited, one would expect that the two columns connected in series would always perform better than the first column. On the contrary, the plot in Figure 2 indicates that decolorization efficiency is almost equivalent in both columns. Additional investigation would be required to determine at what flowrate the process becomes kinetically limited. Obviously, if just one short column is to be used instead of two columns, it must be regenerated twice as frequently to provide for the same color removal.

As an example let us compare two cases. A baseline case has a unit of resin regenerated every 12 hours with a lifetime of 300 cycles. Then a unit of resin will last for 150 days. Let us assume that the color removal requirement is kept the same. If one half of the resin is used with twice as many regeneration cycles, then the resin will have to be regenerated every 6 hours with total of 600 cycles. In the latter case the resin will also last for 150 days, but only one half of resin would be used. Therefore, resin productivity (measured as color removal per unit of resin per unit of time) would be increased by 50%.

These tests have important practical implications. If faster cycling is technically feasible, the resin requirements could be reduced even further. However, due to the necessity of more frequent cycling, it must be proven that resin aging is not directly proportional to the number of decolorization-regeneration cycles.

***Effect of Regeneration on Resin Integrity***

A total of 279 decolorization cycles were carried out in a small one-foot long column to study the resin aging process. This number of cycles represents full resin lifetime in some applications mentioned in the literature.

Initial particle size analysis performed on resin samples resulted in a bimodal distribution, which could have been an indication of fractured resin particles. However, microscopic analysis showed that fine particles were not pieces of fractured resin. After the resin sample was backwashed, the particles size matched the original distribution almost perfectly. The fine solids fraction appeared to represent suspended solids accumulated in the bed. Since feed syrup was processed without preliminary filtration, some fine particles were evidently trapped in the bed.

**TABLE 3**  
**Comparison of New and Used Resin Properties**

<b>Resin sample</b>	<b>% Water content (in Cl form)</b>	<b>Particle size, um (at 50 % level)</b>	<b>Particle size, um (volume weighted mean)</b>	<b>Anion Exchange Capacity, eq/l</b>
---------------------	-------------------------------------	--	---	--------------------------------------

New resin	69.9	800	851	0.82
After 279 cycles	72.2	794	861	0.61

Our results were compared with the decolorization data published by Loker (1983). In this study, similar resin was used in a decolorization application in a cane refinery. Feed color did not exceed 1400 ICUMSA; cycle length was about 18 hours. Breakage of resin beads and resulting high-pressure drop were reportedly causing significant operating problems. Resin had to be changed after about 250-300 cycles because of reduced efficiency, fouling and fracturing.

No effort was made to evaluate the completeness of resin regeneration. The observed 25% reduction in ion exchange capacity suggests that the resin was slowly fouled during the course of the study. However, the effect does not appear to be as drastic as in the Loker (1983) paper, where the reduction in ion exchange capacity exceeded 50% over a period of about 300 cycles. Note that in the above referenced paper cycles were a lot longer and the feed solution color was much lower.

Our initial data show the effect of faster cycling on resin aging. Slower resin degradation than reported in the literature shows some promise that the resin productivity could be increased by 50%. Further investigation is needed to study dynamics of resin fouling and aging.

***Other Observations***

Pressure drop across the resin bed is one of the important factors limiting throughput of industrial equipment. Presence of air or suspended solids in the feed stream is also among the reasons that may cause increased pressure drop. Another potential increase in pressure drop may be related to cooling of syrup in the columns. For example, cooling of 70% DS syrup from 80 to 40EC increases syrup viscosity by a factor of six. We have monitored pressured drop through the bed in the course of our test program. At a flowrate of 3 BV/hour pressure at about 60EC the pressure drop did not exceed 1-2 psi per linear foot of column.

***Potential benefits of fractal decolorizers***

- Fractal decolorization equipment will potentially improve resin productivity, which will make a significant impact on process operating cost.
- Smaller equipment size will also have a positive effect on required capital investment. Peripheral equipment (surge tanks, pumps, etc.) may also become smaller and more economical.
- Relatively fast sweet-off and regenerant displacement observed during the tests implies that reduced requirements for regenerant use and dilution of the product stream may be possible. This has to be quantified in the further tests.
- Short bed systems with frequent cycling appear to be more tolerant to the presence of a small amount of suspended solids. Uniform fluid distribution along with more frequent resin backwash reduces the probability of cluster formation and resin channeling.

- Use of fractal distributors provide very uniform resin surface during exhaustion or regeneration cycles, which results in reduced channeling and resin clumping.
- Shorter cycles may result in less irreversible resin fouling.
- Additional benefits may be realized if higher flowrates can be applied not only for decolorization step, but also for other accompanying steps, such as regeneration, sweet off, etc. Our preliminary observations indicated that this could be accomplished. It would be important to identify the operating limits. Optimization of time for each step of the process will result in a more compact and economical system.

### **Dual function process vessels**

Although decolorization is not widely applied in the beet sugar industry, higher competitive pressure on decreasing color of product sugar is forcing companies to look for some innovative ideas. Being technically attractive, in most cases such applications are not economically feasible. It has been proposed to create multi-functional fractal equipment that can be used for several ion exchange services. For example, equipment can be used for decolorization of thick juice or chromatographic extract in the off-campaign period. During beet slicing campaign the same columns can be used for thin juice softening (with different resin). ARi has designed dual function resin vessels based on fractal liquid distribution technology that are more economical compared to conventional designs. This multi-purpose equipment may be quite useful in many beet plant applications.

Conventional decolorization vessels are usually quite large in size. Replacing resin in such vessels may become a lengthy and tedious task in the factory environment. Because of the smaller resin inventories in fractal equipment, resin changes (cation resin for softening or anion resin for decolorization) becomes more feasible.

### **Conclusions**

- Preliminary data indicate that fractal equipment can be used for decolorization of sugar syrups. As a result, it appears to be possible to reduce required resin inventory by at least 50% due to increased specific throughput.
- Resin integrity only partially depends on number of the regeneration cycles
- Additional research is required to evaluate the effects of process kinetics, cycle length, initial syrup color and type of syrup on decolorization characteristics.
- Use of fractal softening equipment for decolorization (with different resin) could open new opportunities for beet sugar factories. Relatively small resin inventories can be used in both process applications, and resin can be changed quickly.

### **Acknowledgments**

Authors are grateful to Mark Suhr from MS Processing International and Stephen Pease from Rohm and Haas Company for their cooperation and useful advice.

## References

Kearney, M. (2000), Engineered fractals enhance process applications, *Chemical Engineering Progress*, December 2000, pp 61-68.

Kochergin, V, M. Kearney, (2001), Fractal structures for uniform fluid distribution in the sugar industry, *Zuckerindustrie*, Vol.126 (2001), pp.51-54.

Loker, C. (1983), Factory and pilot plant experiences with ion exchange resin employed in decolorization in a carbonatation refinery, *Proceedings of SIT Meeting*, New York, May 15-19, 1983, vol. XLII, paper No.499.

Posted with permission of the ASSBT.

Published in Proceedings from the 32nd Biennial ASSBT Meeting, Operations, San Antonio, Texas, February 26 - March 1, 2003.